

# ROAD CROSSINGS AND CHANNEL GEOMETRY

Stream crossings on perennial streams include:

- Bridges
- Culverts
- Fords

Stream-crossing designs must consider:

- Channel geometry.
- Peakflow capacity, scour depth, and erosion.
- Bedload, ice, woody debris passage.
- Fish passage.
- Road approach grades.
- Floodplain impacts (such as diking with fill).
- Relative cost.
- Potential upstream and downstream effects.



Choosing a location with a stable cross section is critical to project success. This failed bridge had inadequate span and was located on an actively migrating river reach.

STREAM CROSSINGS

## Channel geometry

Channel stability and geometry must be evaluated for all stream crossings. Specifically, the design must take into account vertical (degrading or aggrading) and lateral (bank erosion and migration) instability.

### Vertical instability

- Downcutting can scour and undermine bridge abutments.
- Culverts control streambed elevation upstream, but downcutting may leave the outlet perched above the channel. This tends to restrict fish passage.
- Aggrading channels can fill bridge and culvert cross sections and reduce channel capacity.

### Lateral instability

- Channel migration results in poor alignment of culverts and bridges over time.
- Abutments and road fill may erode with poor alignment.
- Sediment transport is interrupted by poor alignment.

### Location

- Choose a crossing site in a stable, relatively straight reach of channel where possible.
- An incised (deep, narrow) channel cross section is preferred to a wide, shallow location.
- Look up and downstream of the crossing for signs of overall channel stability.
- Choose a location where the road approach will be level or slightly rising.
- Cross the stream perpendicular to the channel whenever possible.

## PEAK FLOW CAPACITY

Instream hydraulic structures should generally be sized to handle the 25-year flood at a minimum, and preferably the 100-year flood. Flood peaks are estimated from regional regression equations, stream gaging stations, or measurements of channel geometry and high water marks. Regional regression equations for Montana provide a reasonably good first approximation (see pages 1.10 through 1.13).

### STREAM CROSSINGS

#### Bridges

Sizing is accomplished by modeling with hydraulic programs, and evaluating backwater conditions on rivers with official floodplain mapping. County floodplain regulations generally allow no more than half a foot of backwater for bridge designs.

Smaller bridge structures should seek to accommodate the bankfull channel width with a clear span, and avoid constricting the channel during major flood events (25-year or greater). Designs should pass estimated flood peaks without significant backwater (pooling) upstream. Relief culverts may be needed in side channels or floodplain areas.

#### Culverts

At a minimum, drainage culverts should be sized to allow passage of a 25-year flood event with a full inlet. On perennial streams, consider sizing the pipe to pass the 100-year event to minimize backwater conditions. The culvert size required to pass a 100-year flood event may be no more than one size larger than that needed for a 25-year flood event. Adequate capacity is especially important on streams with high bedload transport, icing potential, or large amounts of woody debris. Culvert designs with arch, box-shaped, or round pipes with flared inlets provide better peak flow passage than standard round pipes.

#### Fords

Properly sited and constructed fords can replicate natural channel geometry and thus do not normally have peak flow capacity or debris problems. For this reason, fords may be a viable alternative to fixed structures in some situations.



This bridge is set slightly above bankfull, but does not have wingwalls. Location on a meander is not ideal, although upstream rip-rap limits lateral movement. Note that the point bar is still growing under bridge.



This arch pipe is sized to carry the predicted 25-year flow, but causes backwater at the 100-year flow.



A half-hearted effort at armoring the inlets, but note that the pipes are set below grade, which is good for fish passage.

## BEDLOAD / WOODY DEBRIS / ICE CAPACITY

In river systems with high bedload transport, or large amounts of woody debris, the crossing structure must allow for passage of these materials. High bedload transport channels have characteristically large width-to-depth ratios. A bridge or culvert cross section has a much lower, fixed width-to-depth ratio. Even in the absence of large backwater effects, the change in channel hydraulics through a structure can interfere with sediment transport.

### Bridge and culvert design must account for:

- Probable reductions in stream cross section and flow area with gravel deposition (or debris catchment).
- Bedload conveyance through the bridge cross section or culvert.
- Potential changes in channel alignment and bank erosion in adjoining reaches.
- Ice jams and woody debris.

Bridges are generally preferred to culverts where debris, ice, and bedload sediment concerns are significant. Proper sizing for 25-year to 100-year flood conditions generally addresses bedload, debris, and ice concerns by ensuring adequate peak flow capacity. Woody debris passage generally requires 1 or 2 feet of clearance between the bottom of the bridge stringer and the high water surface. Ice passage also requires extra clearance.

A rule of thumb on smaller bridges is to allow at least 2 feet of clearance between the top of the stream bank or floodplain and the bottom of the stringer. If debris jams and icing are a problem, increase the span, do not use center piers, and include ice breakers on the front of piers.



This undersized culvert caused large amounts of gravel to deposit in the channel upstream. Woody debris must be cleaned frequently from the inlet.



This bridge stringer was set below bankfull, and had problems with ice jams and flow capacity.



Debris jams are often associated with center piers on bridge crossings. A clear span is preferable to piers.

## ROAD APPROACHES

### Road approaches require planning

- Road approaches at stream crossings should be graded to rise slightly to meet the abutments.
- Gently rising approaches reduce the potential for storm runoff to deliver road sediments to the channel.
- Stream crossings should be located to accommodate optimal approaches when possible.
- Long, steep grades and side cast fill may deliver significant amounts of sediment to streams.
- Install proper drainage features such as rolling dips, cross drains, road crown, and ditches.
- Follow state BMPs to minimize sedimentation.
- Avoid long road approaches that form a dike across the floodplain.



Stream crossings with long, steep downhill approaches often route sediments directly to the channel.



Stream crossings on shallow channels with broad floodplains must rise to meet the bridge, or the bridge will end up being too low, like this one.

### Guidelines

- Maintain road approaches at 2 percent grade or less, and preferably rising to meet the abutment.
- Drainage features should be provided every 200 feet on long downhill approaches. Route drainage through a filtration zone before entering a stream.
- Select a crossing location to avoid long road segments that sidecast road fill into the stream or floodplain.
- Stabilize road fill with reseeded, slash windrows, hay bales, erosion fabric, or silt fence to prevent sedimentation of channels.
- Some level of hydraulic or structural engineering analysis should be performed for most bridge crossings.

#### CAUTION:

- Long, steep road approaches to the stream crossing should be avoided.
- Proper drainage must be provided to avoid routing surface water runoff into stream channels.
- Long, in-sloped ditches must not channel runoff into the stream or floodplain.
- Avoid diking the floodplain with long elevated road approaches across broad flat valley bottoms.

ROAD APPROACHES (continued)

When possible, road approach fills for bridges and culverts should be placed low and near the floodplain elevation so the road will be overtopped before the bridge or culvert is washed out. This allows the relatively inexpensive repair of replacing road fill or surface instead of replacing a bridge or large culvert. By placing road approaches low, the road approach acts like an emergency spillway, passing flood waters that the bridge or culvert is unable to pass. Examples of road approach fills across floodplains and channels are shown below.

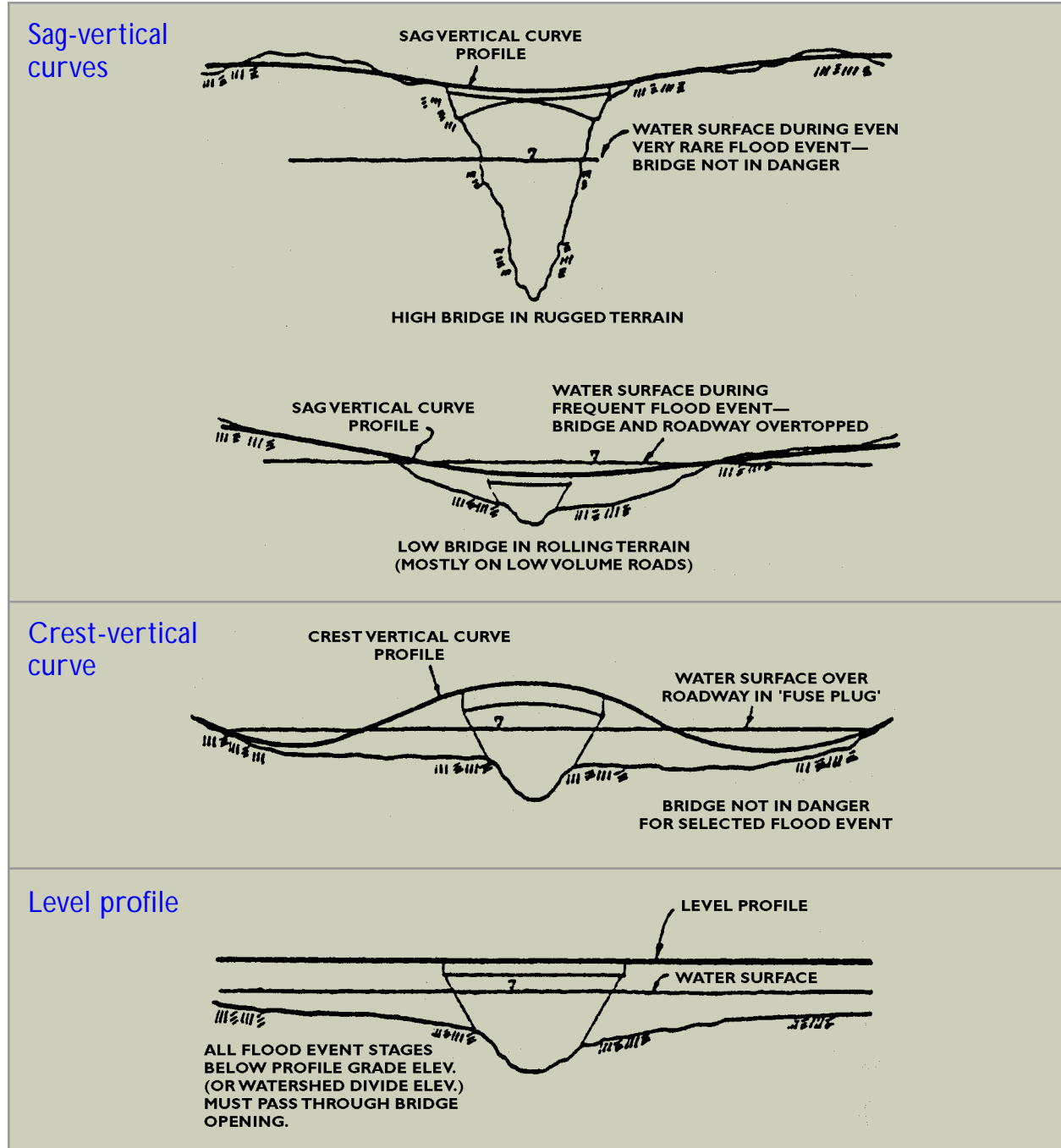

STREAM CROSSINGS

From FHWA HEC-20, *Stream Stability at Highway Structures*

# BRIDGES

Well designed bridges are the preferred option for permanent stream crossings because they usually have the least impact on channel process and fish passage. Most bridges should be designed by an engineer, with hydraulic and structural analysis.

## Typical small bridge construction

### Timber

- Timber bridges are most applicable to stream crossing up to about 30 feet.
- Timber is suitable for light load requirements.
- Stringers can be raw logs, milled beams, or laminated beams.
- Raw log abutments can be labor intensive and have a short project life.
- Equipment needs for construction are modest.

### Steel

- Railcars can be used for bridges 30 to 65 feet. Longer spans usually require piers.
- Steel I-beam, wood, or corrugated steel decking for 20 to 100+ foot spans.
- Long project life is an advantage of steel.
- Steel allows a longer clear span than timber, reducing the need for center piers, which can catch debris.

### Concrete

- Typical small bridge design is a pre-stressed slab with poured concrete abutments.
- Use beam construction for larger bridges.
- Heavy load capacity and minimal beam depths for the slab (versus stringers and beams) are an advantage.
- An engineered design is usually required.
- Often used for abutments and wingwalls.
- Long project life.

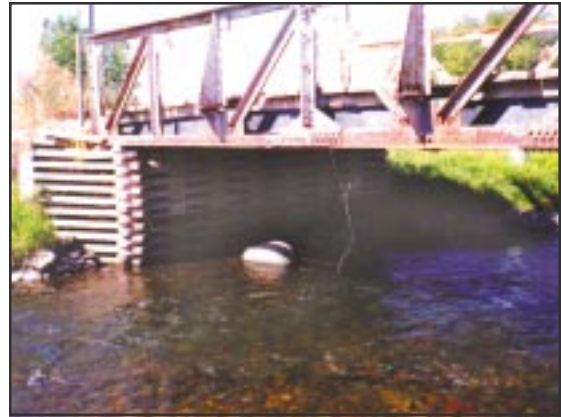

Wood cribbing has a limited life, but can work well for smaller bridges. This bridge has adequate clearance for ice, debris, and peak flows.



Railcar bridges are popular and fairly solid, but often are not installed properly. This one is set low relative to bankfull, but it is a temporary installation.



The structural beam on many railcars hangs low and ends up falling below bankfull elevation.

# ABUTMENTS AND PIERS

## Abutments

- Abutment design must account for scour depth in the stream bed to prevent undermining of footings.
- Generally, the minimum depth for footings is below the frost line and piers should be well below the lowest point of the streambed at the crossing.
- Footings may need to extend 10 feet deep or more in unstable rivers.
- For most smaller bridge projects, observing the depth of nearby pools gives a good indication of minimum footing depth.
- Abutments can be constructed from a variety of materials, and should include wingwalls to stabilize road fill on the approaches.

## Bridge Piers

Avoid designs with center piers if possible because they tend to catch debris, causing scour and channel instability during peak flows.

- Wood spans exceeding 30 feet, or steel spans approaching 50 to 60 feet, require piers for support.
- Longer bridge spans requiring heavy load capacity should have an engineering review.



A well-constructed abutment has adequate wingwalls to support road fill.



Concrete can make good abutments, provided the footing is placed below scour depth. This footing should be 2 feet lower.



A low stringer in an aggrading channel does not leave much room for water. Note that the beam hangs low in the center and restricts peak flow capacity and debris passage.



Stacked median barriers often make poor abutments. The absence of wingwalls, footings, and a 1:1 fill slope mean this bridge is likely to require additional maintenance.

# CULVERTS

Culverts can perform well on stream crossings, provided they are properly sized to handle peak flows. Fish passage must be considered when selecting and placing a pipe.

## Culvert styles

- **Round** – standard corrugated metal pipe.
- **Pipe Arch/Squash** – less backwater and lower final fill elevation than round pipe.
- **Arch** – wide open bottom facilitates passage of fish, debris, and sediment (available only in corrugated metal).
- **Structural Plate** – larger size of arch pipe, bridge substitute.
- **Plastic Round** – similar to round corrugated culvert, easy to handle, but can be harder to install properly. Indefinite project life.
- **Concrete Box** – flat concrete bottom is poor for fish passage.



Undersizing pipes to save money is a poor strategy.



Bottomless arch or box pipes (shown here) promote fish passage and create less backwater than round pipes of the same size.

## Design and installation

- Size culverts to handle 25-year (minimum) to 100-year flood.
- Sizing is generally adequate when bankfull cross-sectional area is equaled.
- Inlet water elevation at design flow should not exceed the elevation of top of pipe (no headwater).
- Place culverts on grade, or slightly below grade of natural stream bed. Footings for bottomless culverts must be set well below the expected scour and frost depths.
- Place culverts below grade (1 to 2 feet) if oversized pipes are used to facilitate fish passage.
- Culverts must be long enough to accommodate road fill slopes.
- Inlet and outlet of pipe should be armored with rock to prevent scouring.
- Installation should be completed as quickly as possible during low flow to minimize impacts to fisheries and water quality.
- Install culverts at right angles to the channel whenever possible.

### CAUTION:

- Proper siting of culvert crossings in a stable, relatively straight reach is critical.
- Culverts must adequately pass peak flows, debris, ice, and allow fish passage.
- Culvert crossings should be avoided in aggrading streams, or on laterally unstable stream locations.
- Fish passage considerations may require oversized pipes, baffled culverts, open-bottomed arches, or bridges.
- Corrosive soil or water conditions may damage metal pipe.
- Multiple side-by-side culverts should be discouraged because they catch debris and have a greater tendency to wash out.



## CULVERTS *(continued)*

### Culvert siting

#### Headwater channels (Rosgen A)

- Typically steep gradient channels with deep fill over pipe.
- Culvert length must be adequate to accommodate fill slopes.
- Fish passage is frequently poor due to shallow or high-velocity flows or long culverts.
- Open bottom arches are an alternative to enhance fish passage when required.
- Culverts can be oversized and then set below stream grade to promote fish passage.

#### Mid-valley channels (Rosgen B)

- Moderate gradient channels, often cobble bottom with narrow floodplains.
- Adequate ice and debris passage can be difficult to accommodate with pipes.
- Oversized culverts placed below grade (1 to 2 feet) can promote fish passage by allowing a gravel bottom to form in pipe.

#### Valley bottom channels (Rosgen C/D)

- Low gradient channels often with poor lateral stability.
- Undersized pipes can cause gravel deposition and channel instability upstream.
- Site selection in stable reach is critical.
- Bridges and open bottom arches should be considered to accommodate channel dynamics and debris.

#### Valley bottom channels (Rosgen E)

- Sinuous, narrow, deep channels, often silt or fine gravel beds with broad floodplains.
- Round and especially arch pipes can work well.
- Avoid raising fill across floodplain on approach road to crossing.

#### Downcutting channels (Rosgen G)

- Vertically unstable channels with downcutting.
- Scouring downstream of pipe will leave the “downcutting” pipe perched above grade at the outlet unless the stream grade is stabilized.



Concrete box pipes frequently have poor fish passage characteristics because of the smooth, flat bottom.



The shotgun (or perched outlet) culvert impedes fish passage, and can result from placing the culvert too high, or installing the culvert in a channel that has a tendency to downcut without grade control downstream of the outlet.



Multiple pipes are sometimes acceptable, but they can catch debris. Consider aluminum box or squash pipes.

# CULVERT DESIGN AFFECTS FISH PASSAGE

STREAM CROSSINGS

## Poor fish passage

1. Steep culvert.
2. Fast, shallow flow through pipe.
3. High jump at outfall.
4. No pool at outfall entrance.

Typically found in Rosgen A-, G- and sometimes B-channels. These installations can be complete barriers to fish migration and must be avoided on spawning tributaries.

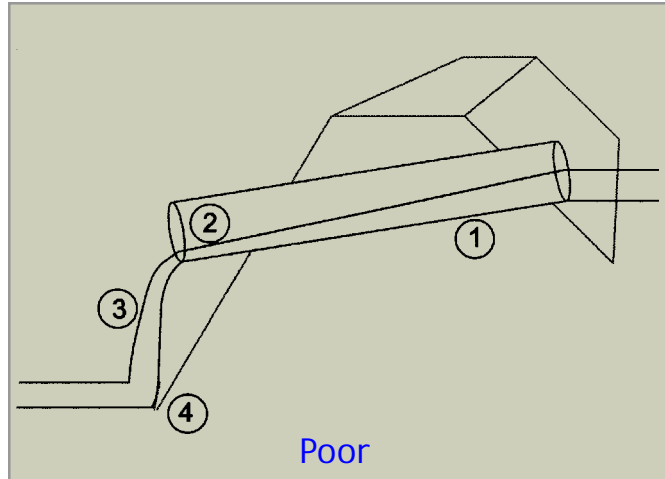

## Improved fish passage

### Constructed approach pools

1. Flatter grade.
2. Deeper, slower flow.
3. Constructed approach pools.

Useful in all channels with poor entrance conditions, especially Rosgen B, C, and G channels. Stable approach pools may be difficult to construct in wide, shallow channels.

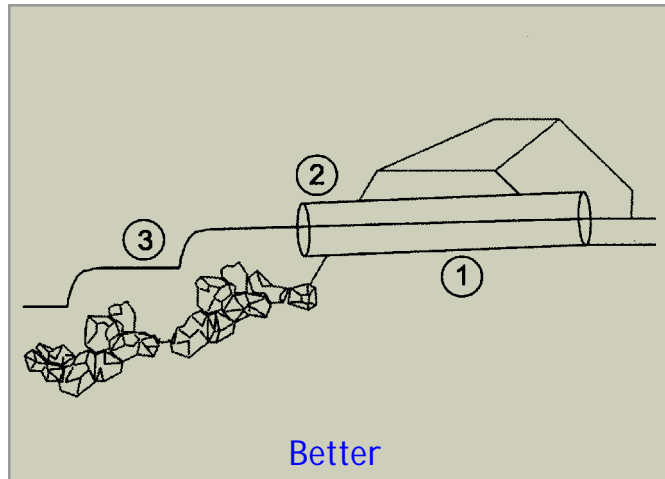

## Optimal fish passage

### Culvert set below natural stream grade

1. Flat grade (less than 2 percent).
2. Deeper, slower flows allow formation of natural bed in pipe.
3. Pool at outfall.
4. Oversize pipe set 1 to 2 feet below grade.

Steeper gradient streams may require rock pools. Shorter culverts are easier for fish to pass.

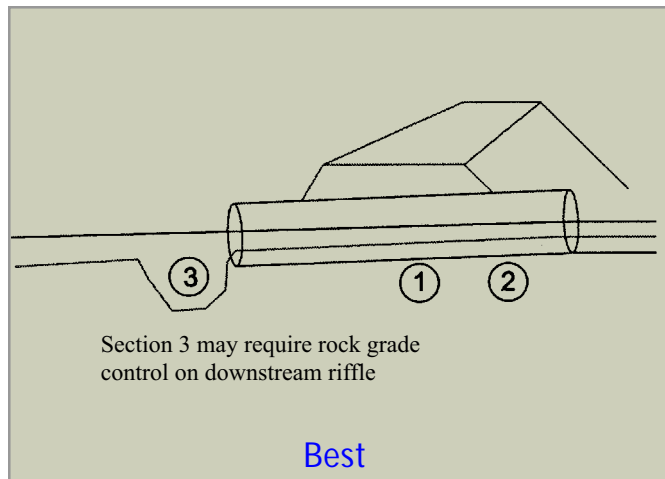

## FORDS

Fords are used as a temporary crossing in wide shallow channels with gravel or cobble bottoms and infrequent traffic.

### Applications

- Temporary crossings, gravel/cobble bottoms/light traffic.
- High width-to-depth ratio channels.
- Emergency access.
- Only used if impacts to channel stability, fisheries, and water quality are minimal.
- Generally, fords are not appropriate for permanent crossings.

### Design and construction techniques

- Unreinforced fords can be effective in solid substrate with light traffic.
- With heavier traffic (such as log trucks) or softer gravel channel bottoms, channels generally require some type of reinforcement.
- Reinforcement materials include rock, timber, concrete plank, geogrid, and filter fabrics.
- Size rock to resist scour and stream shear stress.
- Use filter fabric to prevent losing rock into soft channel bottoms.
- Geogrid rock/gravel-filled mats or fabrics are designed according to load requirements.
- Timber can be used for temporary crossing on small channels (such as winter logging with snow bridge over logs).
- Match the natural cross section of the stream as closely as possible to protect streambed stability.
- Consider the season ford will be used to minimize impacts to fisheries or water quality.



Fords may be a viable alternative for intermittent or shallow wide channels that resist other solutions.



To protect water quality, avoid fords on perennial channels with poor approaches and inadequate drainage control.

### CAUTION:

- Fords are not appropriate for deep narrow channels (Rosgen E type) or soft channel bottoms without reinforcement.
- Fords are not appropriate for most permanent installations unless traffic is very infrequent.
- Channel dynamics can be impaired if ford cross section does not match natural channel cross section.
- Sediment releases with traffic may cause unacceptable harm to fisheries.
- Fords may be subject to travel restrictions.
- Road approaches must not direct road surface runoff into channel.
- Fords are often seasonal crossings at normal or low flows only.

